



# RODAN(TAIWAN)LTD.

## INFRARED EMITTING DIODE

### 1.ELEMENT APPEARANCE

PAGE : 1 / 4

Model No.	Material	Lighting Color	Resin Color
RT4-09ENT	AlGaAs	Non-Visible	Water Clear

### 2.ABSOLUTE MAXIMUM RATINGS AT Ta=25°C

Characteristic	Symbol	Rating	Unit
Forward direct current	IFM	700	mA
Reverse voltage	VRM	5	V
Operating temperature	Topr	-40 to +85	°C
Storage temperature	Tstg	-40 to +100	°C
Power dissipation	Pd	1.4	W

### 3.ELECTRO-OPTICAL CHARACTERISTICS AT Ta=25°C

Characteristic	Symbol	Condition	Min.	Typ.	Max.	Unit
Radiant intensity	Ie	IF=350mA		55		mW/sr
Forward voltage	VF	IF=350mA		1.5	2.0	V
Reverse current	IR	VR=5V			10	μA
Peak emission wavelength	λp	IF=350mA		855		nm
Spectral band width @ 50%	Δλ	IF=350mA		25		nm
Rise time/Fall time	tr/tf	IF=350mA		25/15		ns
Viewing angle	2θ 1/2	IF=350mA		123		deg.

※Radiant Intensity Measurement allowance is ±15%

※Forward voltage Measurement allowance is ±0.1V

※Peak emission wavelength Measurement allowance is ±1nm

### 4.DIMENSIONS UNIT : mm

Tolerance is ±0.25mm unless otherwise specified.

SIGN : 1.CATHODE

2.ANODE

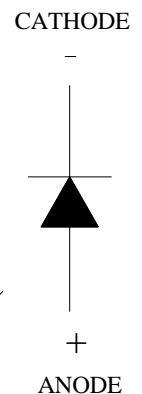
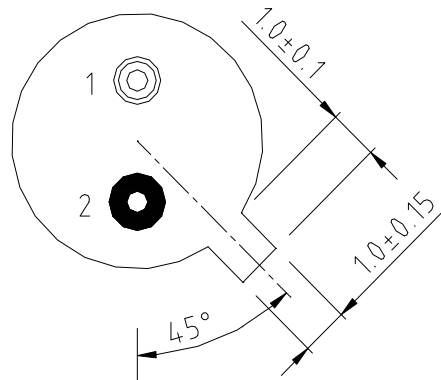
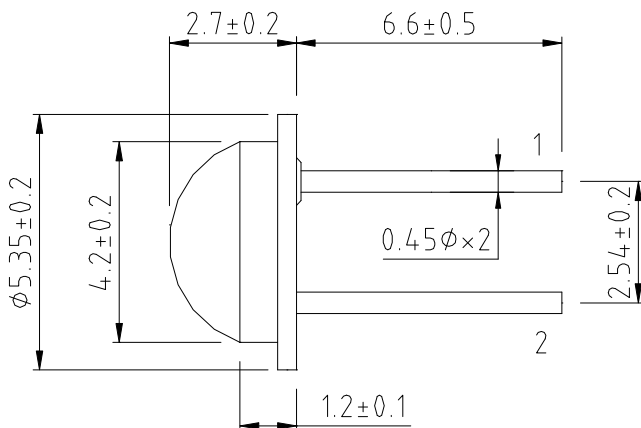

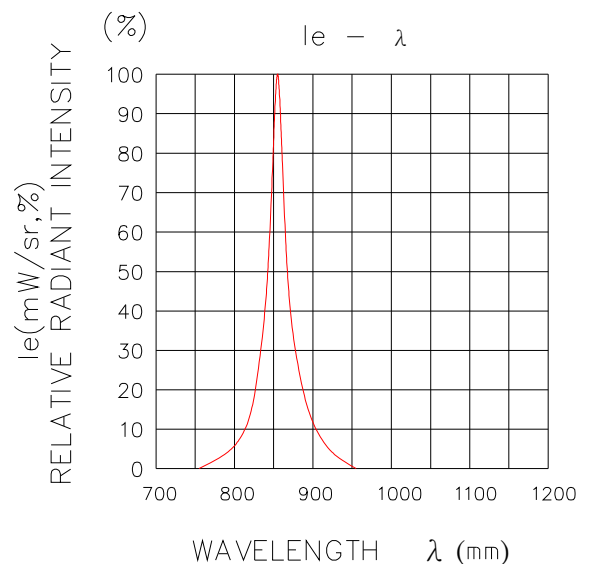
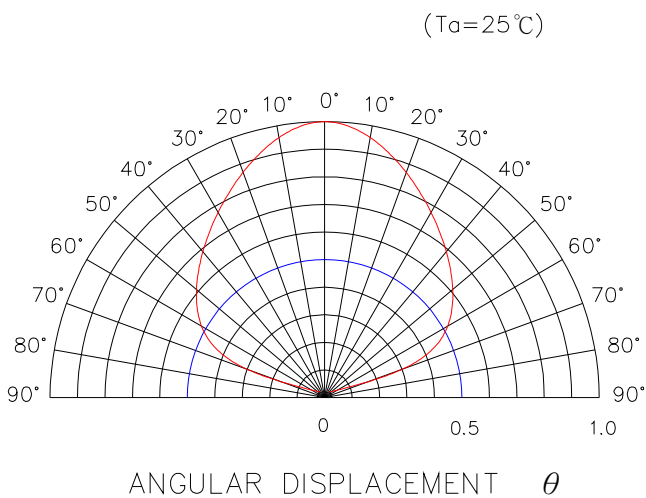
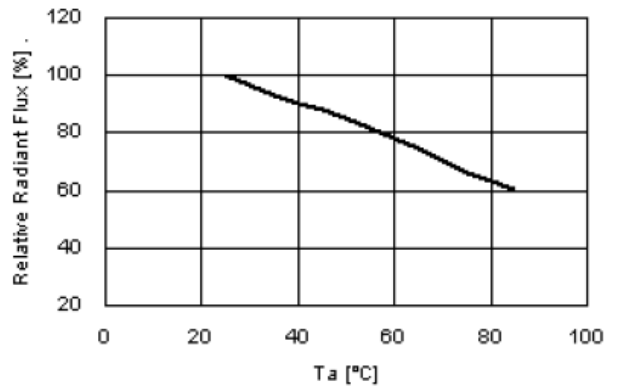
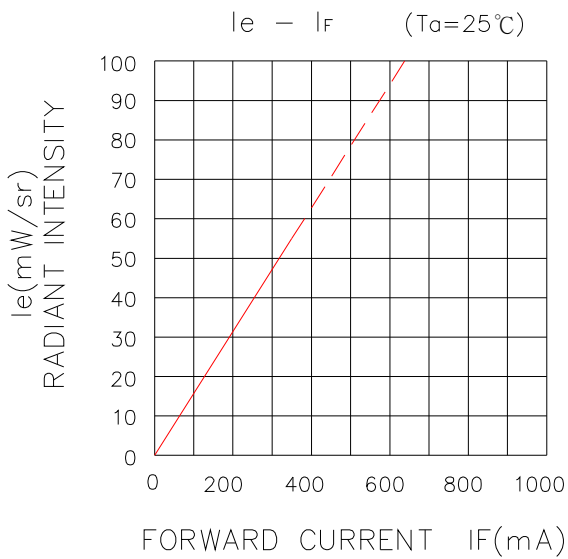
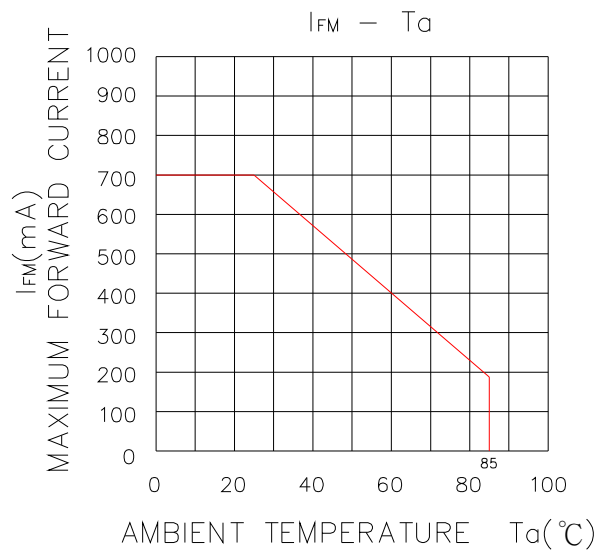
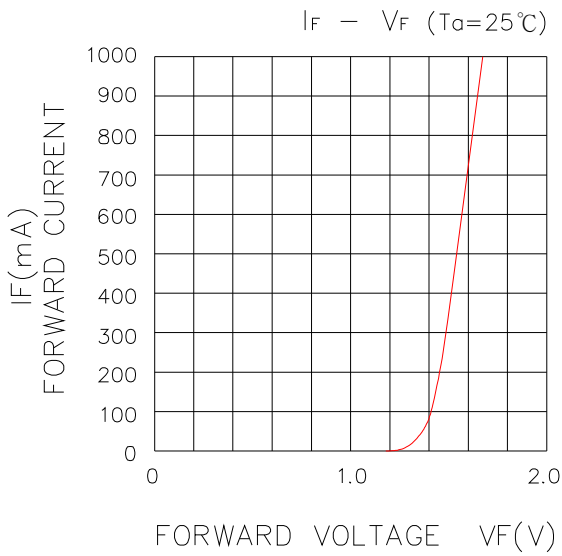



## Soldering Profile

**Compliant with the following condition :**

- (1) Leaded quantity of product below 100 ppm
- (2) Lead-free process

Shape	Lead Frame Type
Hand soldering	1.Temp.at tip of iron : 300 °C max.(30W max.) 2.Soldering time : 3 sec max. 3.Distance : 3 mm MIN (from solder joint to case)
DIP soldering	1.Preheat temp : 100 °C max , 60 sec max. 2.Bath temp : 260 °C max. 3.Bath time : 3 sec max. 4.Distance : 3 mm MIN (From solder joint to case)
Recommended soldering profile	1.Preheat temp. : 100 °C , 50 sec max. 2.Peak temp. : 260 °C max. 3.Peak time : 3 sec max. 4.Duration above: 200°C , 3 sec max.

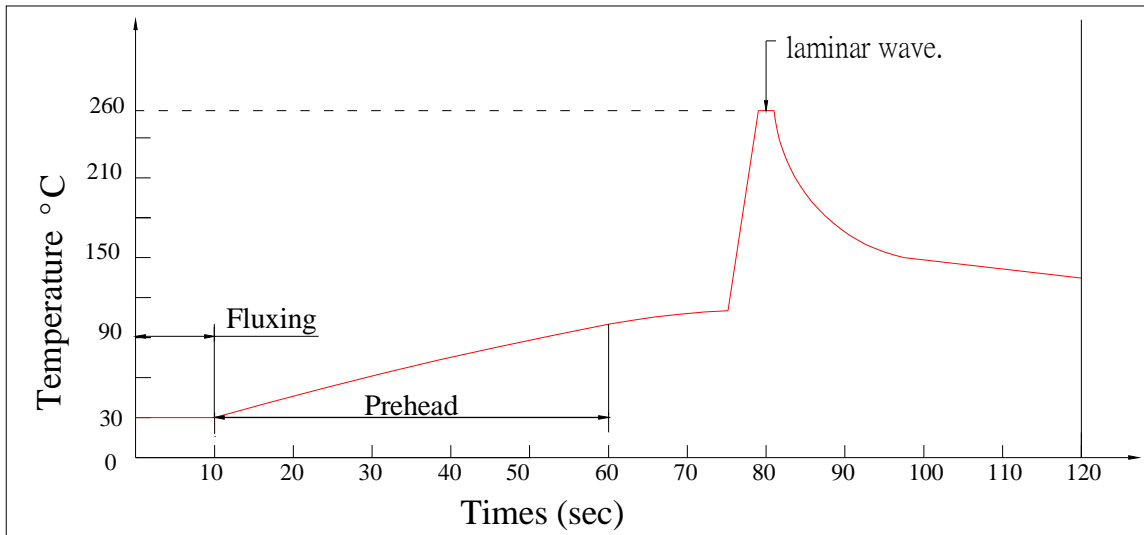

SMD Type		
Profile Feature	Solder : Lead-Free	Solder : Low Lead-Free
Preheat temp	150-180 °C , 4°C/sec max. 120 sec max.	130-170 °C , 4°C/sec max. 120 sec max.
Peak temp	245 °C max. , 5 sec max.	213 °C max. , 25 sec max.
Duration above	217 °C , 60 sec max.	200 °C , 40 sec max.

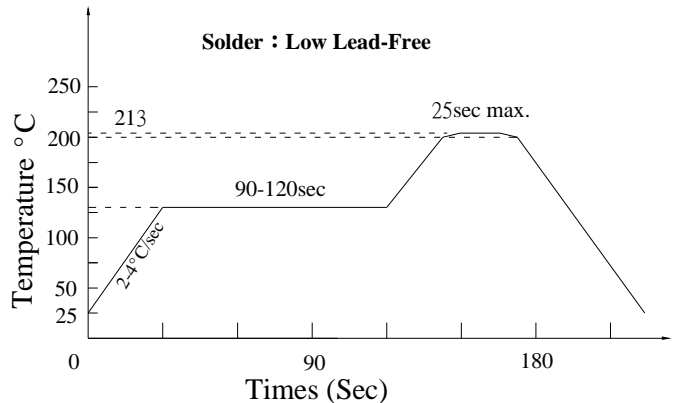
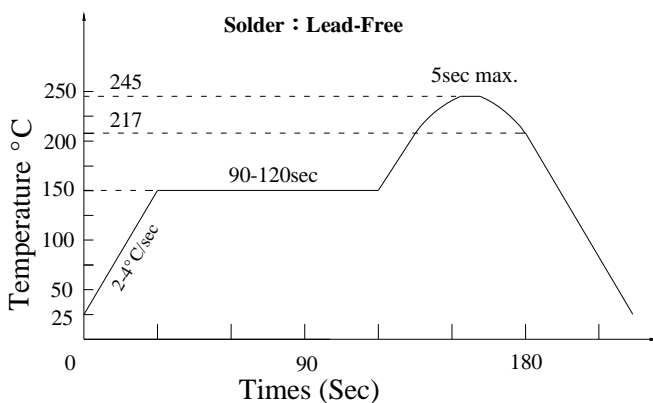



## Reliability Test Items

### CONDITIONS :

The reliability of products shall be satisfied with items listed below.

NO.	<u>Item</u>	Condition	Time / Cycle	Criteria	Ac / Re	Sample Quantity
1	Soldering Heat Test	260°C	5 sec	Open / Shot	0 / 1	60 pcs
2	Thermal Shock	0°C (5min) ~100°C (5min)	20 Cycles	Open / Shot	0 / 1	60 pcs
3	High Temp. Storage	100°C	1000 Hrs	Open / Shot	0 / 1	60 pcs
4	Low Temp. Storage	-40°C	1000 Hrs	Open / Shot	0 / 1	60 pcs
5	Temperature Cycle Test	-40°C~85°C	100 Cycles , 200Hrs	Open / Shot	0 / 1	60 pcs
6	High Temp. High Humidity Test	60°C, 90% RH	1000Hrs	Open / Shot	0 / 1	60 pcs
7	DC Operation Life Test	IF=350mA	1000Hrs	Power decay	≤30%	60 pcs