



RODAN(TAIWAN)LTD.

PHOTODIODE

PAGE : 1 / 4

1.ELEMENT APPEARANCE

DATE : DEC.05.2005.

Model No.	Lighting Color	Resin Color
RT3-2324SDBS	Non-Visible	Black Color

2.ABSOLUTE MAXIMUM RATINGS AT Ta=25

Characteristic	Symbol	Rating	Unit
Maximum reverse voltage	V _{RM}	50	V
Operating temperature	T _{opr}	-25 to +75	
Storage temperature	T _{stg}	-25 to +100	
Lead soldering temperature (5mm from body) 260 for 5sec.			

3.ELECTRO-OPTICAL CHARACTERISTICS AT Ta=25

Characteristic	Symbol	Condition	Min.	Typ.	Max.	Unit
Reverse breakdown voltage	V _{BR}	I _R =100 μ A	35			V
Reverse dark current	I _D	V _R =10V			10	nA
Light current	I _L	E _e =0.5mW/cm ² ,@940nm	5.4	9		μ A
Junction capacitance	C _j	V _R = 3V , f = 1MHZ		3		pF
Wavelength of the max. sensitivity	p			900		nm
Radiant sensitivity area	A			0.74		mm ²
Turn-on/Turn-off Time	ton/toff	V _R =5V , R _L = 50		10/10		ns
Viewing angle	2 1/2			35		deg.

4.DIMENSIONS UNIT : m/m

SIGN : 1.CATHODE

2.ANODE

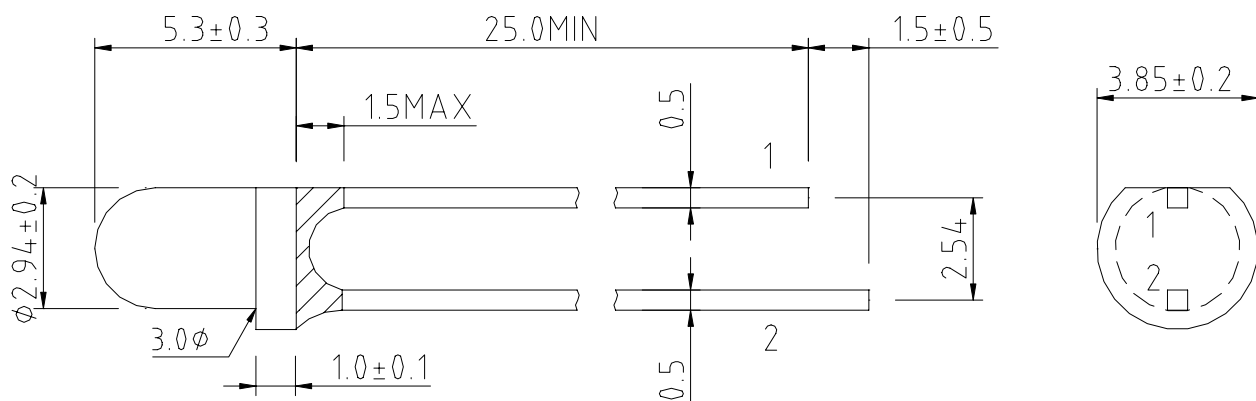



RODAN(TAIWAN)LTD.

Model : RT3-2324SDBS

PAGE : 2 / 4

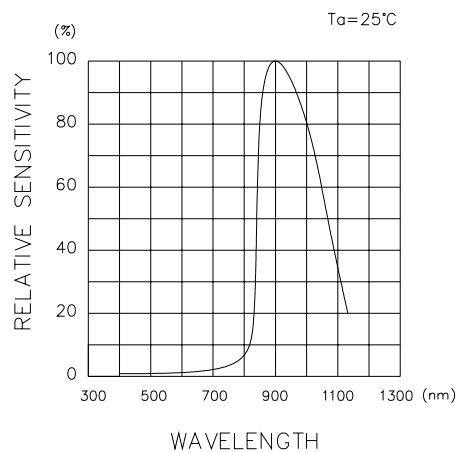
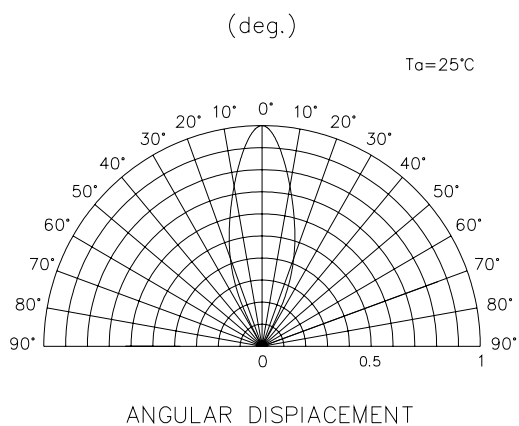
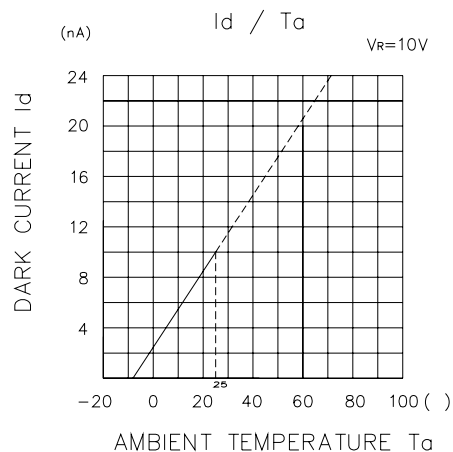
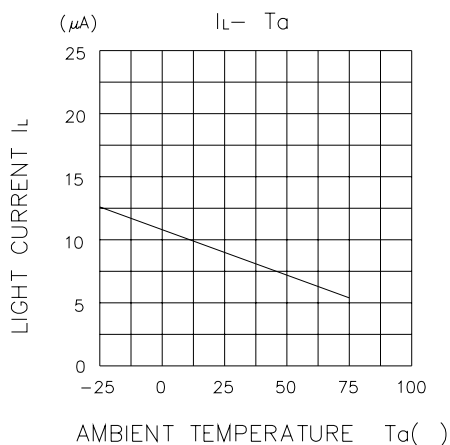
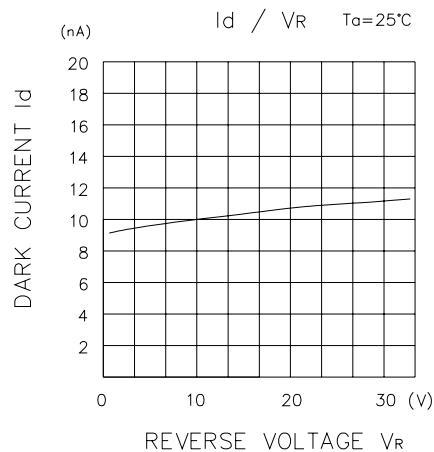



Lamp Condition

In the automatic mounting of LAMP LED to the L/F, any bending, expanding, and pulling forces against the LAMP LED should be minimized to prevent the electrical failures or mechanical damaged.

Reflow Soldering and Temperature Profile

The LAMP LED is designed for the reflow soldering process. Too high temperature or too large temperature gradient may cause the electrical and optical failures.

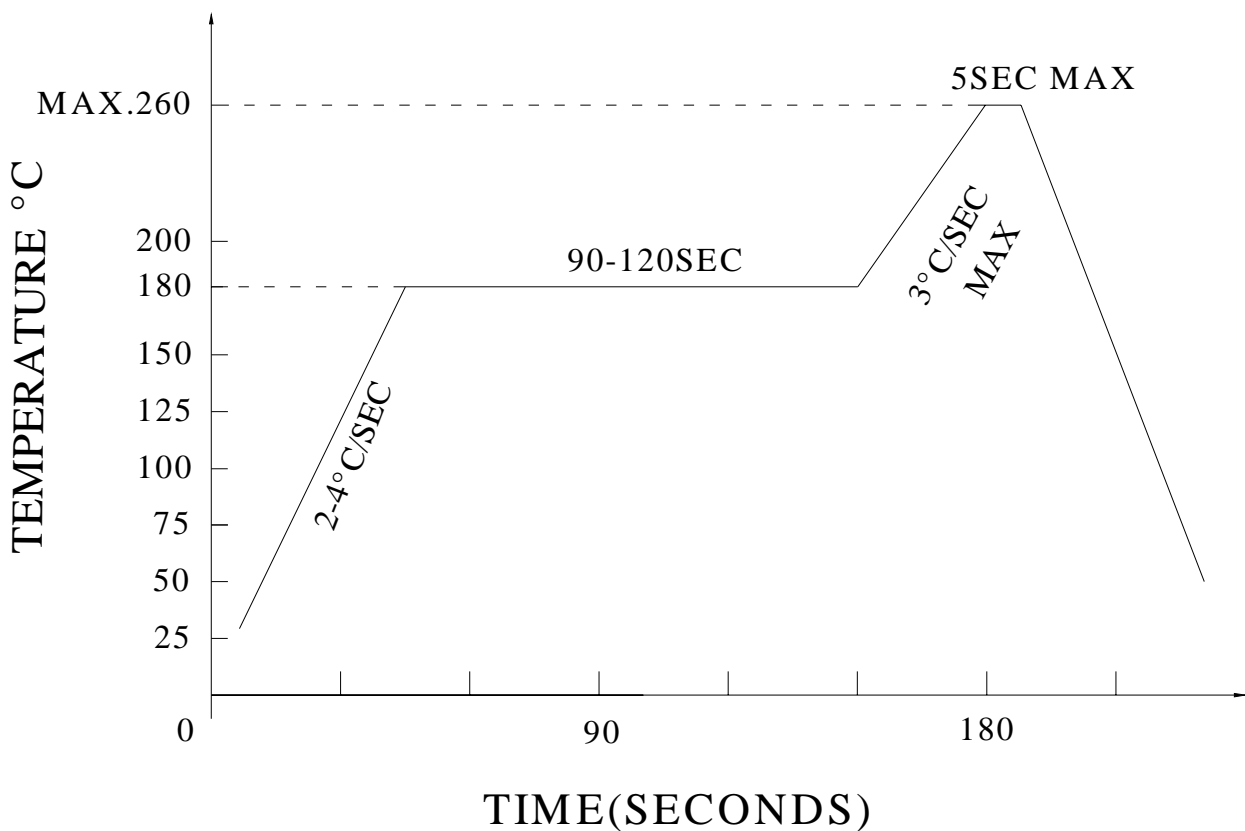



Reliability Test Items

CONDITIONS :

The reliability of products shall be satisfied with items listed below.

NO.	Item	Condition	Time/Cycle	Number of Damaged
1	Soldering Heat Test	260	5 sec	0/60
2	Thermal Shock	0 (15sec) ~100 (15sec)	20 cycle	0/60
3	High Temp. Storage	100	1000 Hrs	0/60
4	Low Temp. Storage	-25	1000 Hrs	0/60
5	Operation Temperature Cycle Test	-25 ~75	100 Cycles , 200Hrs	0/60
6	High Temp. High Humidity Test	60 , 90% RH	1000Hrs	0/60
7	Operation Life Test	Room Temp. @IR940nm	1000Hrs	0/60